

NOTE:
Please read all instructions
carefully before using this
product

Table of Contents

Safety Notice

Hardware Identifier

Assembly Instruction

Parts List

Model
PR-HE

Retain This

Manual for
Reference

03-22-10

OWNER'S
MANUAL



Deluxe Back Trainer PR-HE

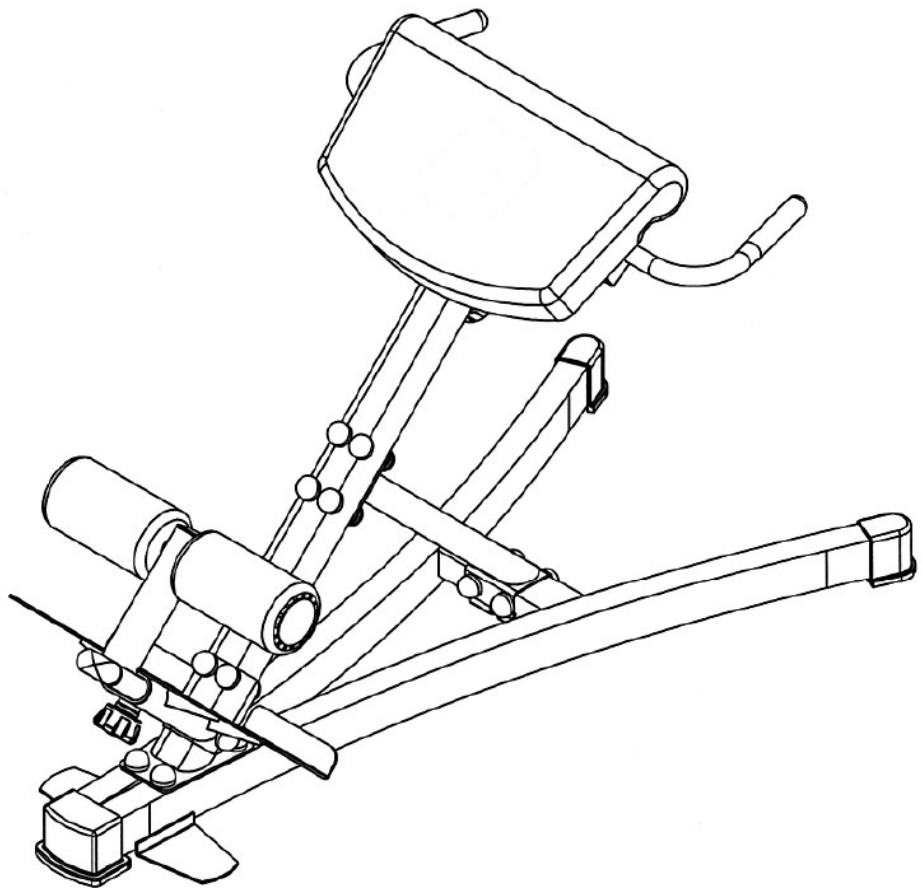

TABLE OF CONTENTS

BEFORE YOU BEGIN.....	1
IMPORTANT SAFETY NOTICES.....	2
HARDWARE PACK.....	3
ASSEMBLY INSTRUCTIONS.....	5
EXPLODED DIAGRAM.....	13
PARTS LIST.....	14

BEFORE YOU BEGIN

Thank you for selecting the Deluxe Back Trainer PR-HE. For your safety and benefit, read this manual carefully before using the machine. As a manufacturer, we are committed to provide you complete customer satisfaction.

IMPORTANT SAFETY NOTICE

PRECAUTIONS

This exercise machine is built for optimum safety. However, certain precautions apply whenever you operate a piece of exercise equipment. Be sure to read the entire manual before you assemble or operate your machine. In particular, note the following safety precautions:

1. **Keep children and pets away from the machine at all times. DO NOT leave children unattended in the same room with the machine.**
2. Only one person at a time should use the machine.
3. If the user experiences dizziness, nausea, chest pain, or any other abnormal symptoms, STOP the workout at once. CONSULT A PHYSICIAN IMMEDIATELY.
4. Position the machine on a clear, leveled surface. DO NOT use the machine near water or outdoors.
5. Keep hands away from all moving parts.
6. Always wear appropriate workout clothing when exercising. DO NOT wear robes or other clothing that could become caught in the machine. Running or aerobic shoes are also required when using the machine.
7. Use the machine only for its intended use as described in this manual. DO NOT use attachments not recommended by the manufacturer.
8. Do not place any sharp object around the machine.
9. Disabled person should not use the machine without a qualified person or physician in attendance.
10. Before using the machine to exercise, always do stretching exercises to properly warm up.
11. Never operate the machine if the machine is not functioning properly.

WARNING: BEFORE BEGINNING ANY EXERCISE PROGRAM, CONSULT YOUR PHYSICIAN. THIS IS ESPECIALLY IMPORTANT FOR INDIVIDUALS OVER THE AGE OF 35 OR PERSONS WITH PRE-EXISTING HEALTH PROBLEMS. READ ALL INSTRUCTIONS BEFORE USING ANY FITNESS EQUIPMENT. WE ASSUME NO RESPONSIBILITY FOR PERSONAL INJURY OR PROPERTY DAMAGE SUSTAINED BY OR THROUGH THE USE OF THIS PRODUCT.

SAVE THESE INSTRUCTIONS.

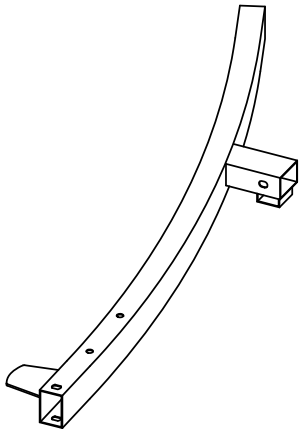

①

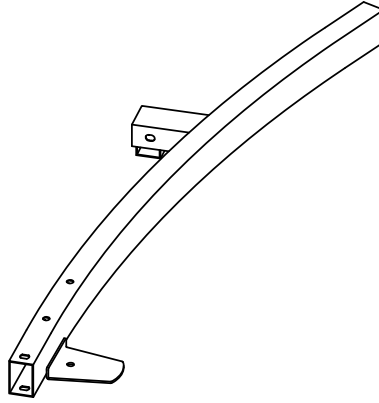

②

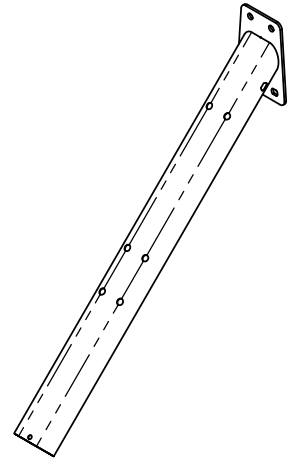

③

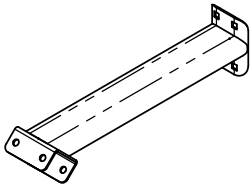

④

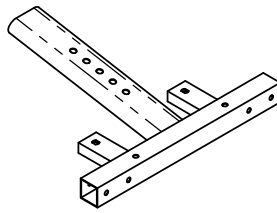

⑤

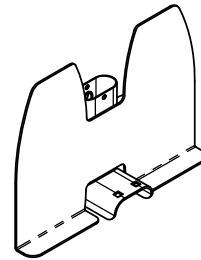

⑥

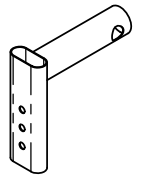

⑦



⑧

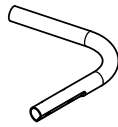

⑨

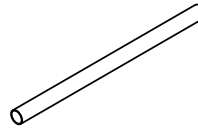

⑩

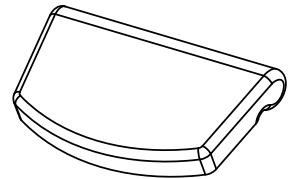

⑪

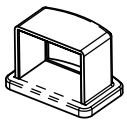

⑫



⑮



⑰

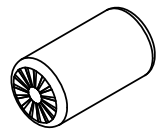

⑱



⑲

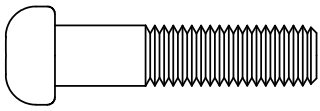

24

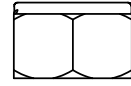
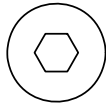

30

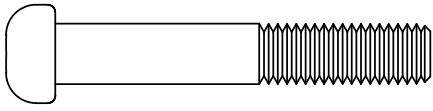

25

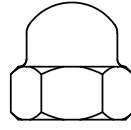
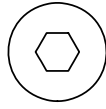

31

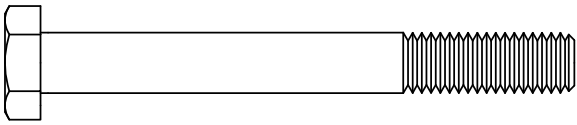

26

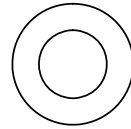

32

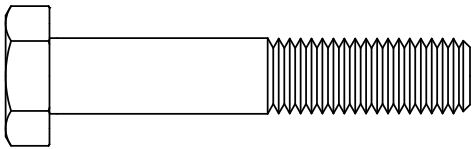

27

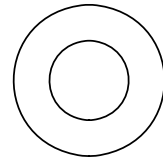

33

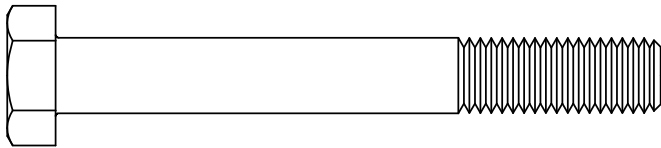

28



34

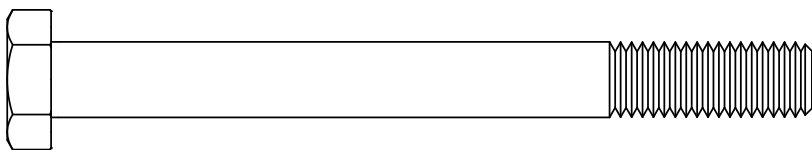

29

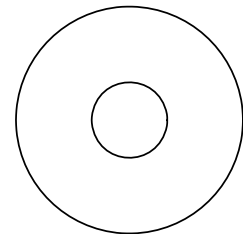

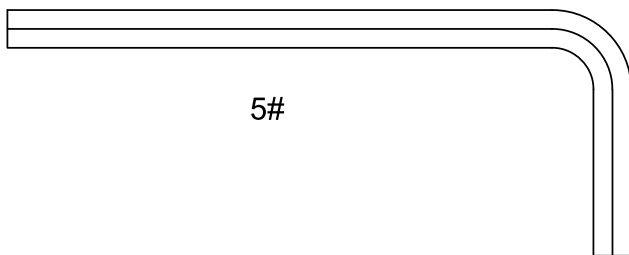

35

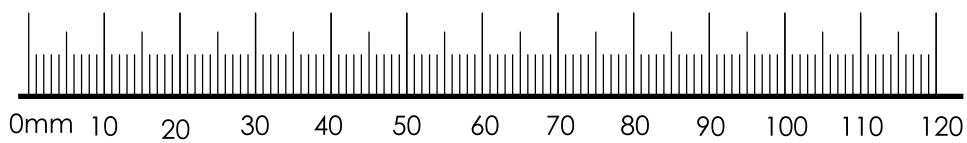

5#

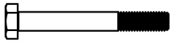

③③		4	φ20×φ10.5
③⑤		4	φ10×φ30×2
③⑩		4	M10
②⑧		4	M10×80mm

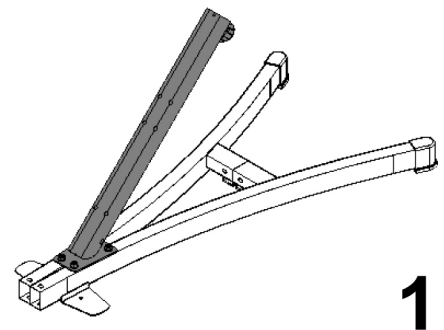
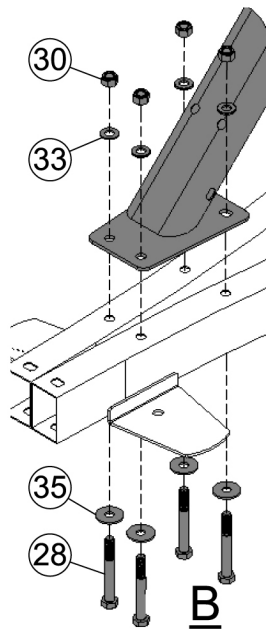
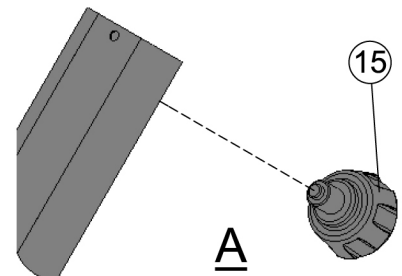
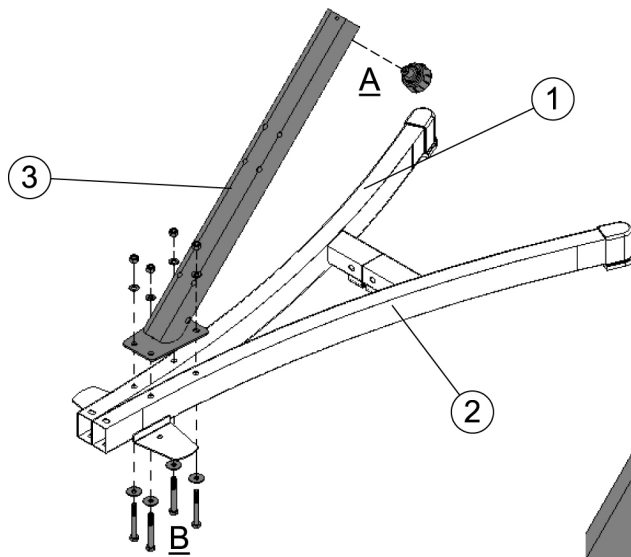
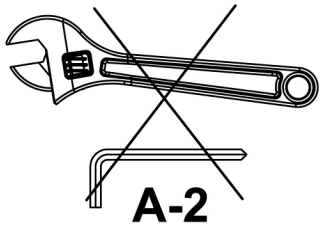

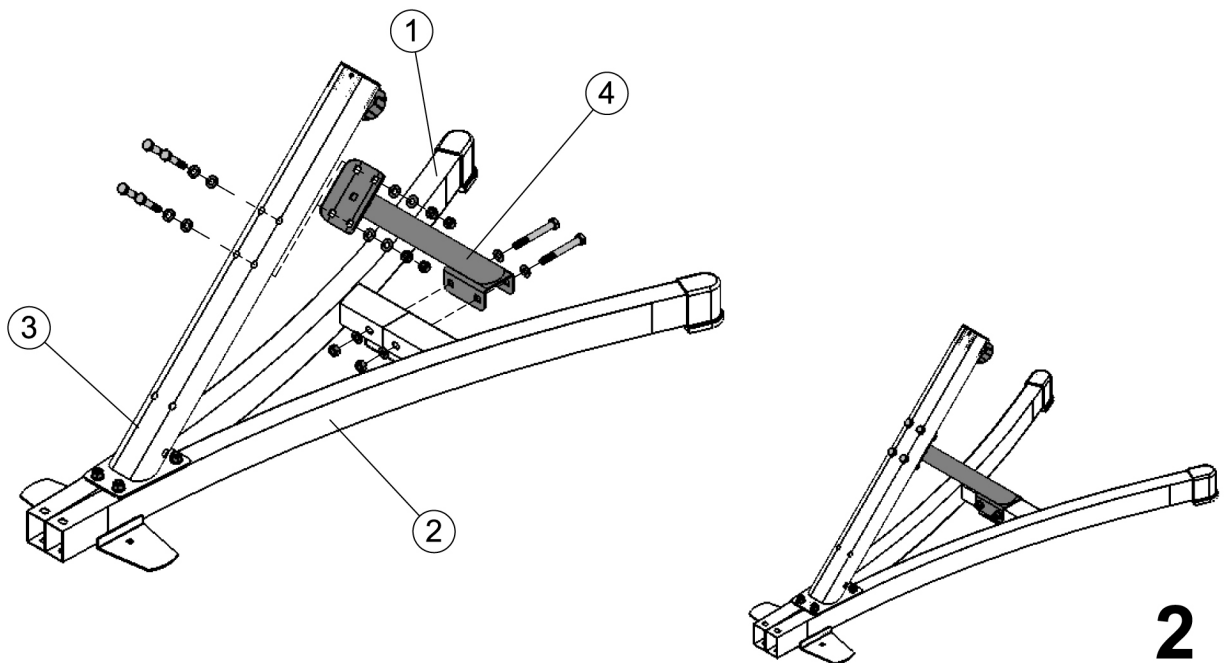
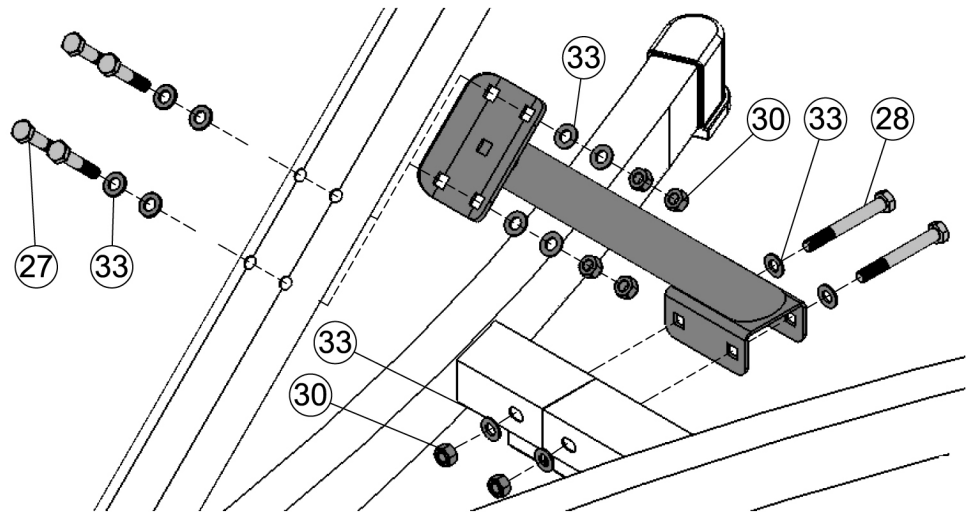
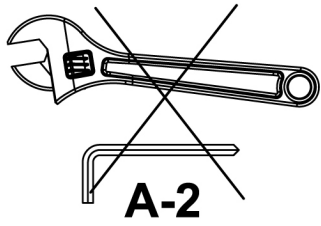

③③	⊙	12	φ20×φ10.5
③①	⊞ ⊞	6	M10
②⑦	⊞	4	M10×55mm
②⑧	⊞	2	M10×80mm

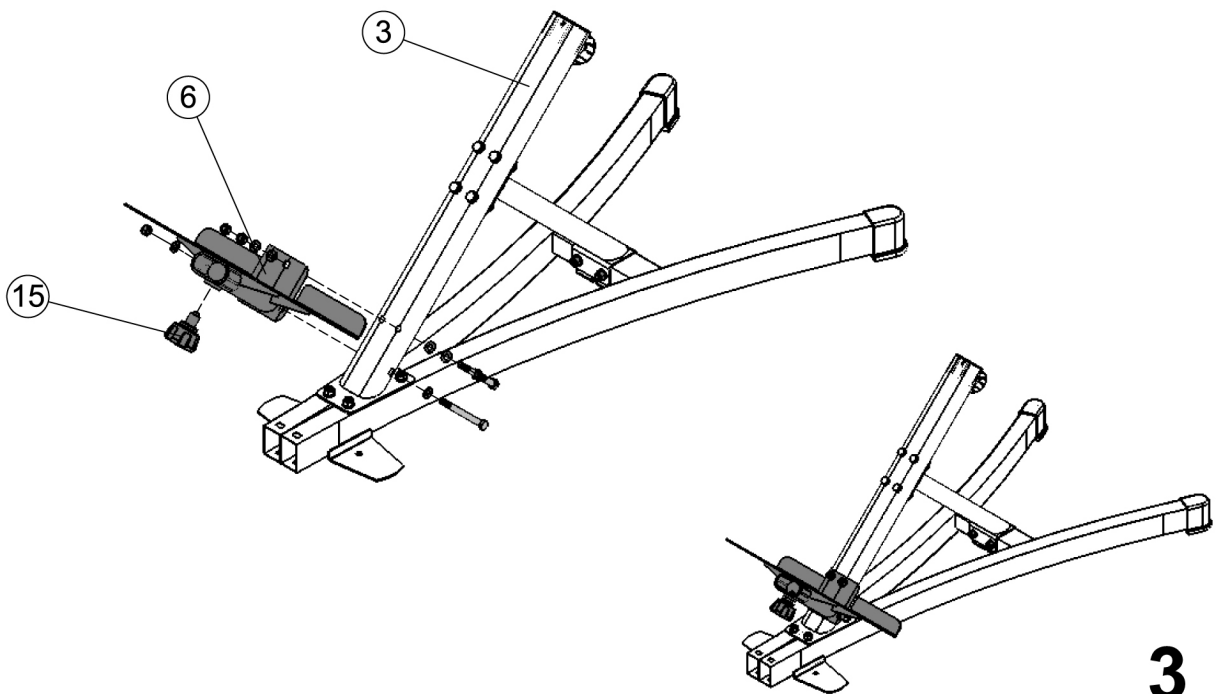
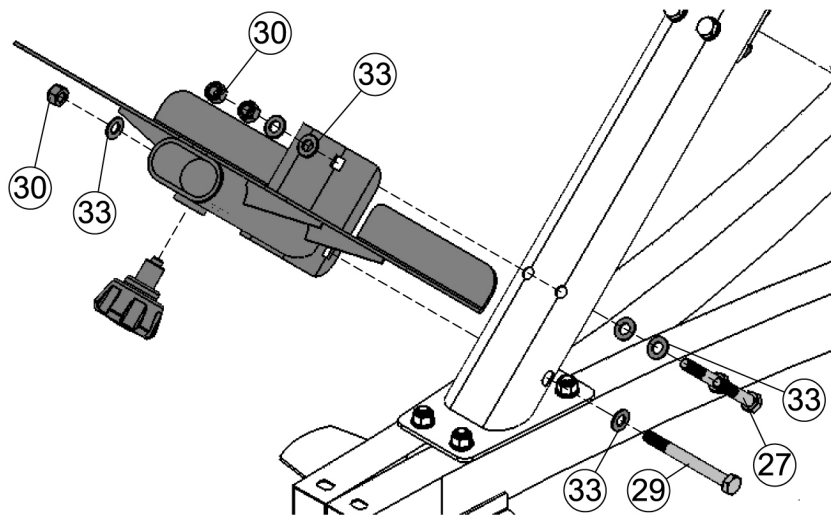
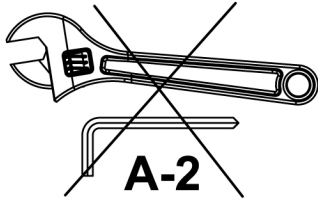

(33)		6	$\phi 20 \times \phi 10.5$
(30)		3	M10
(27)		2	M10×55mm
(29)		1	M10×100mm

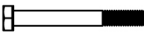

③②		4	$\phi 16 \times \phi 8.4$
③④		4	$\phi 16 \times \phi 8.4$
③①		4	M8
②⑥		4	M8×70mm



A-1

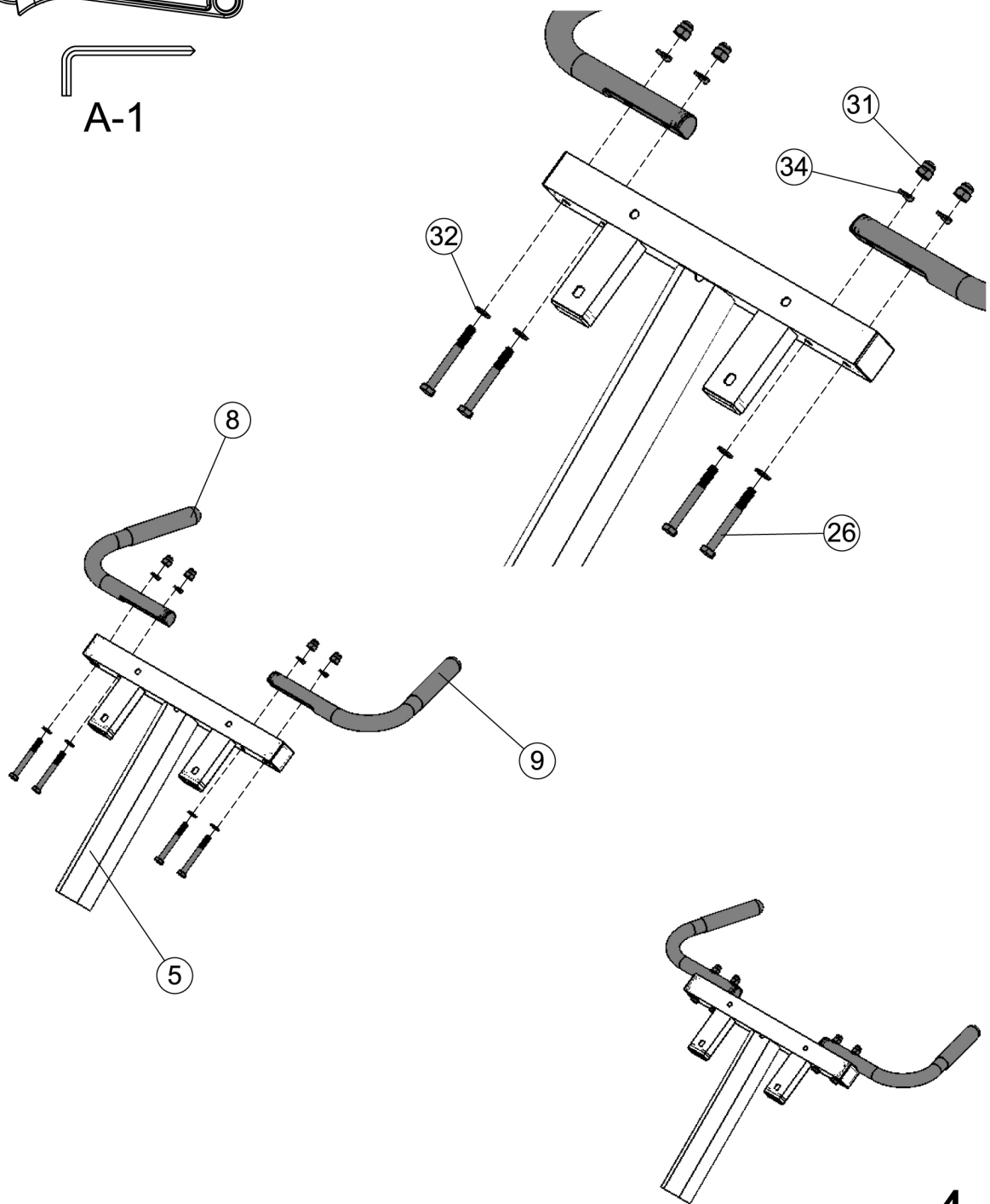

4

③② ⊙ 4 φ16×φ8.4

②④ [Bolt] ⊙ 2 M8×35mm

②⑤ [Bolt] ⊙ 2 M8×55mm

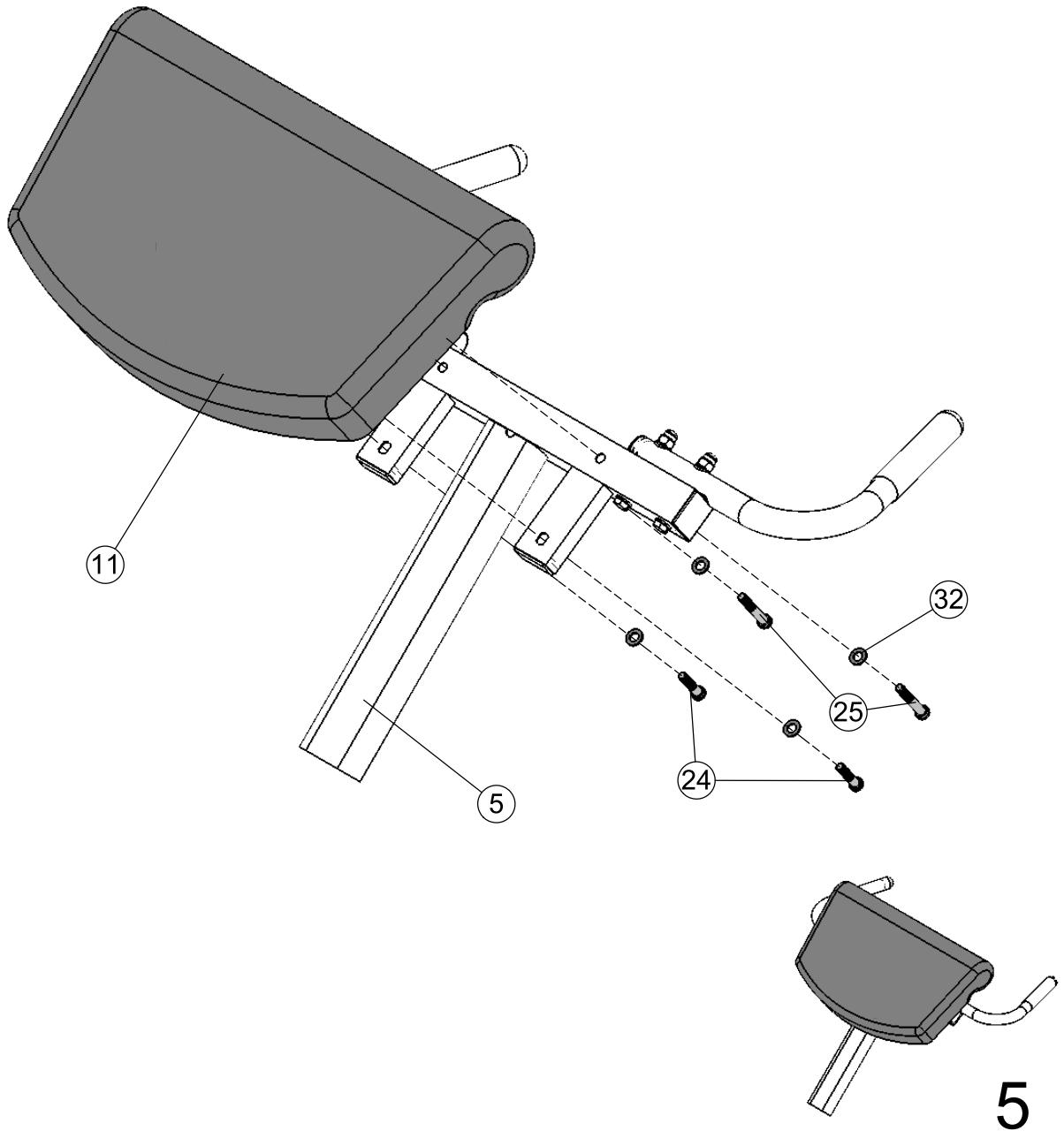
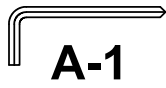
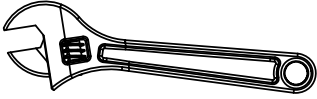

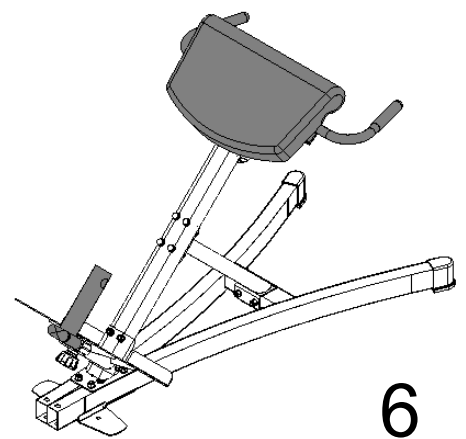
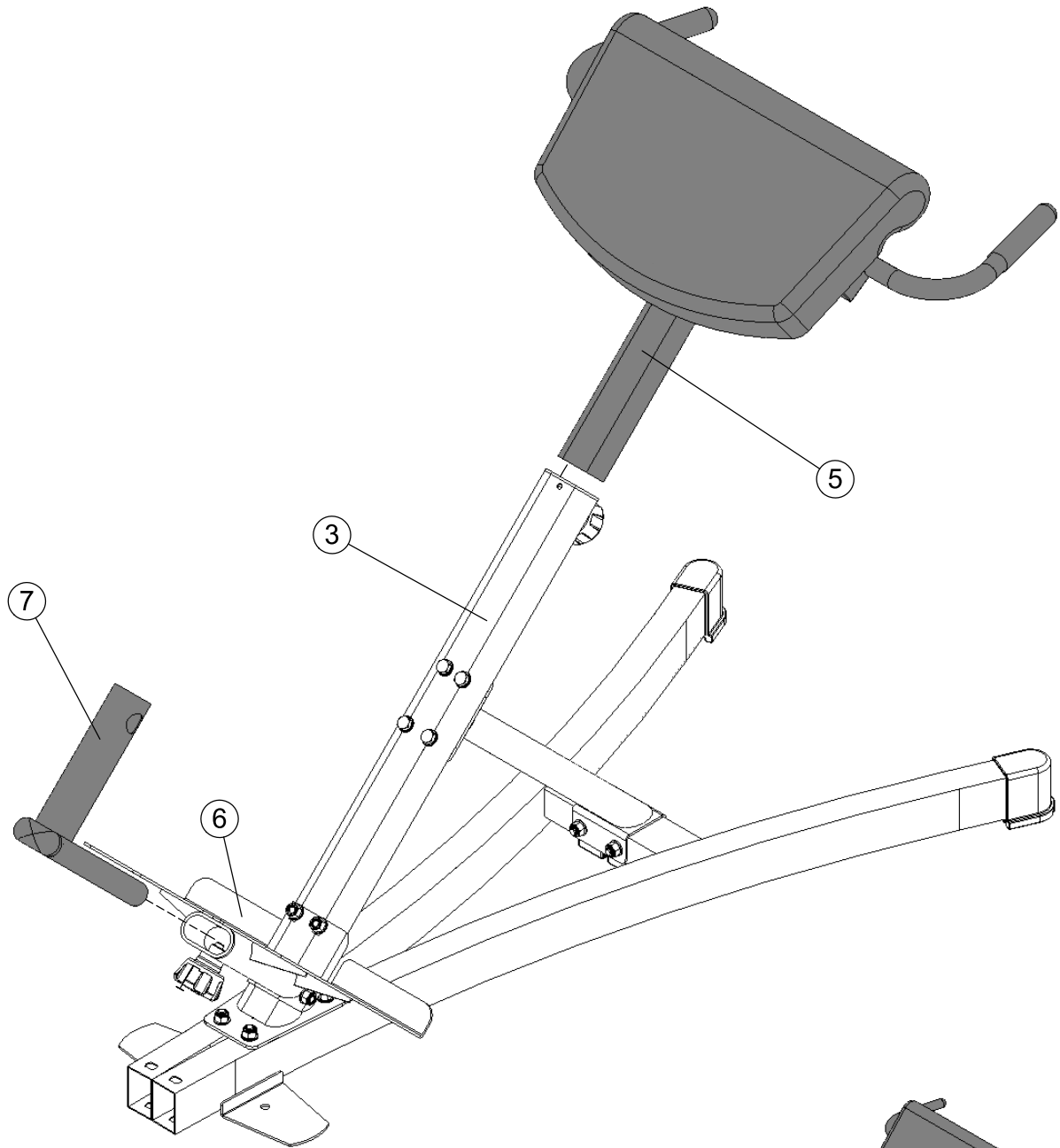

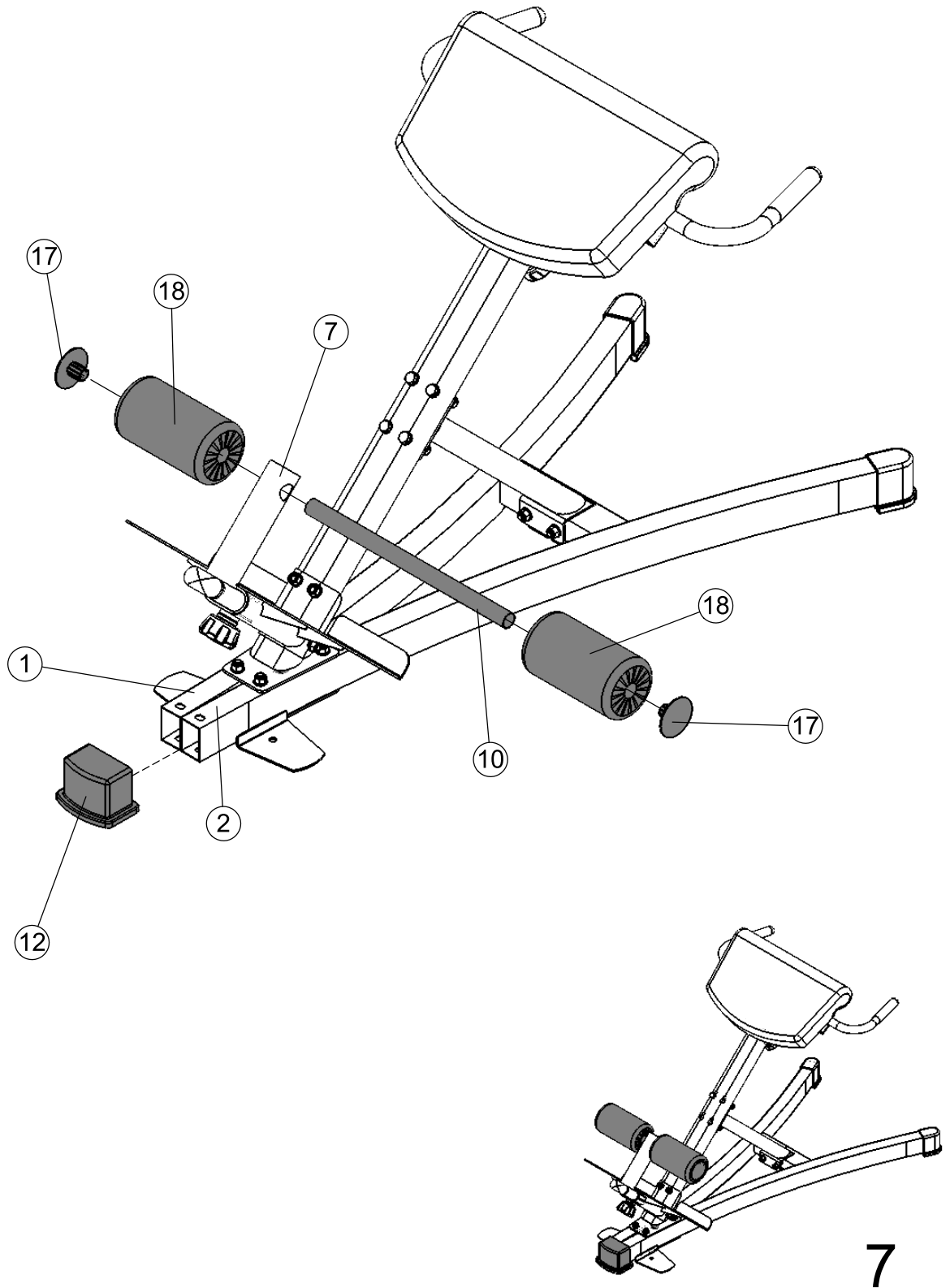

19



22

M10

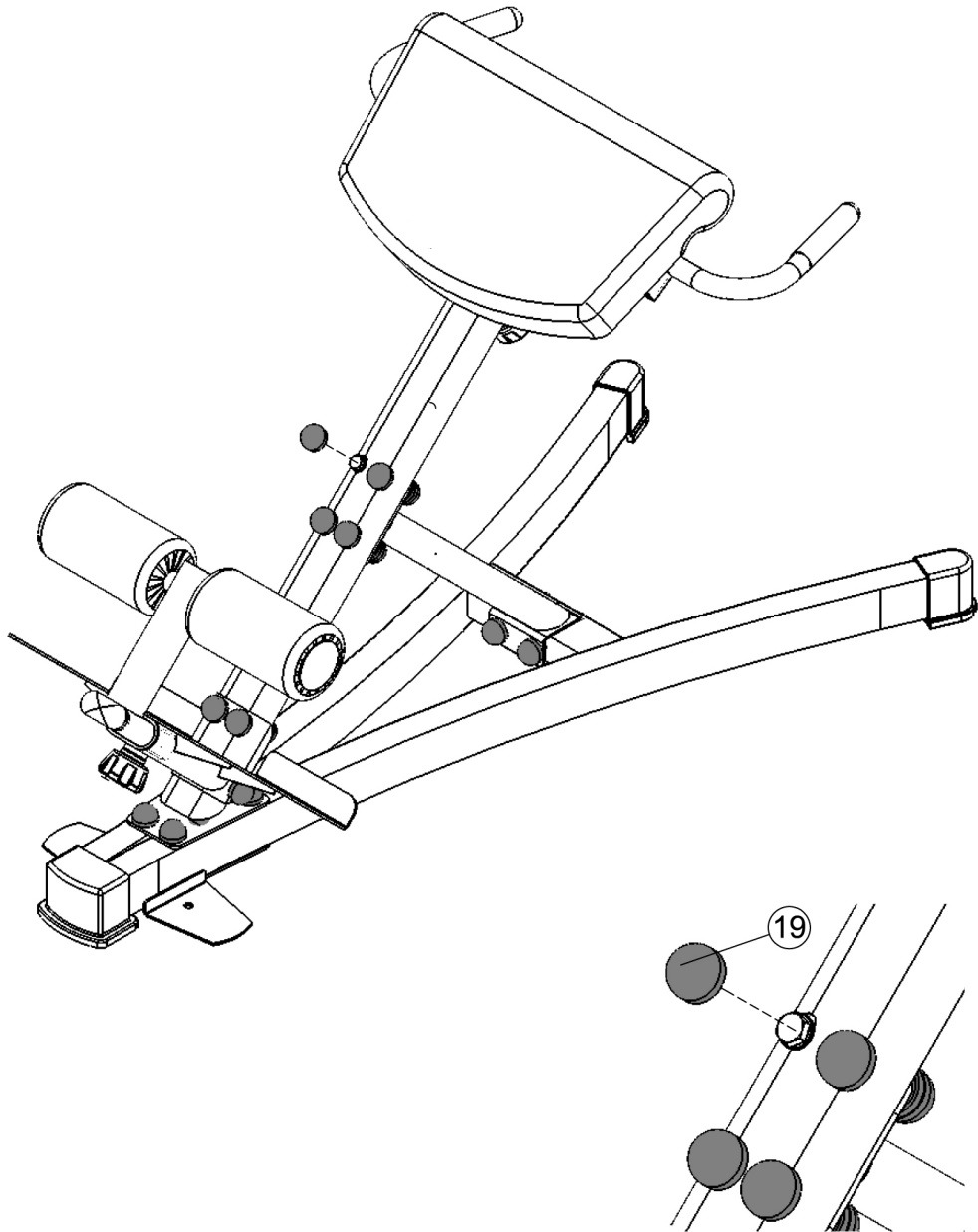

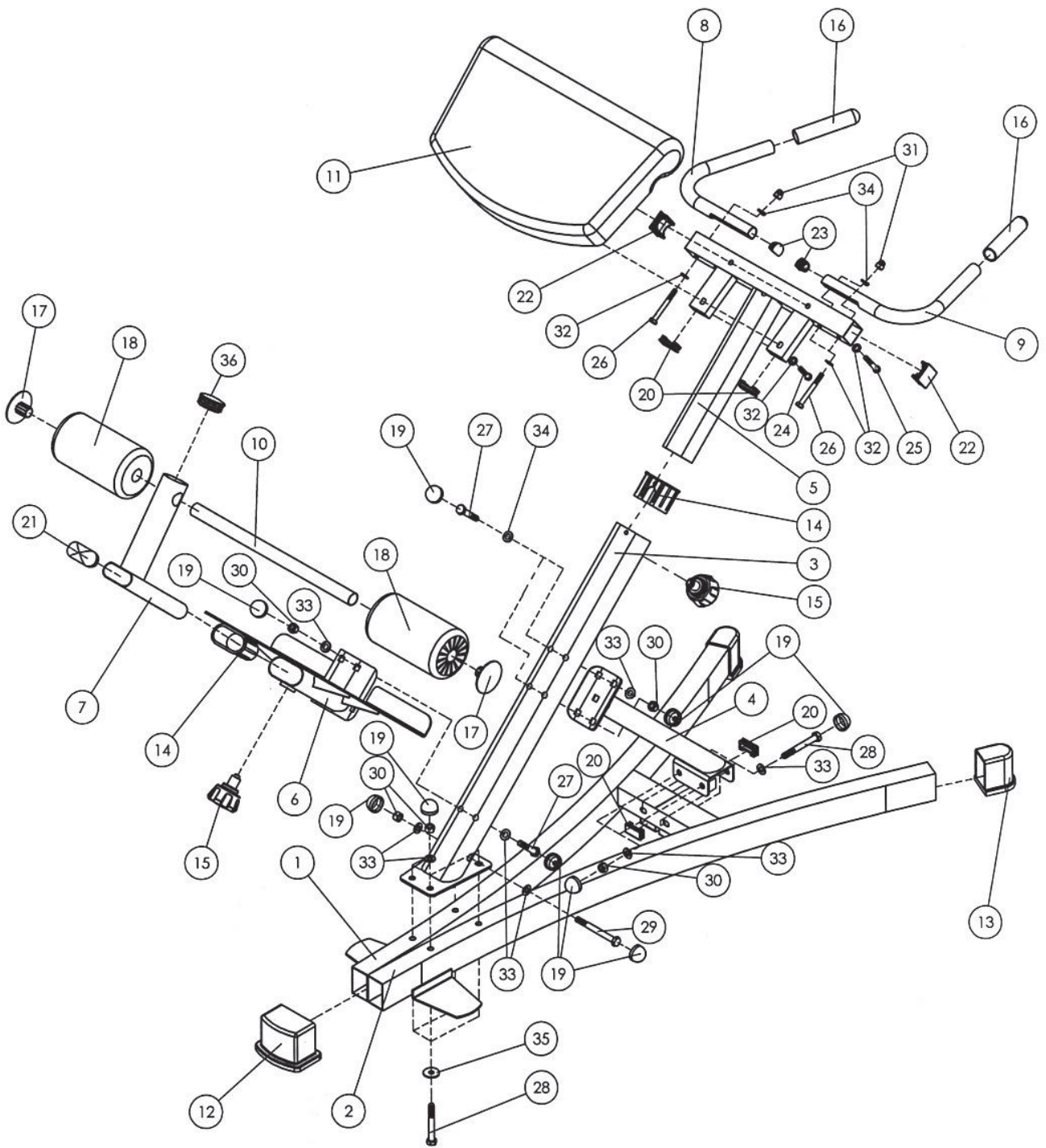

Part list

NO.	DESCRIPTION	SIZE	QTY
1	LEFT BASE FRAME		1
2	RIGHT BASE FRAME		1
3	MAIN FRAME		1
4	DIAGONAL SUPPORT		1
5	BACKREST SUPPORT		1
6	FOOT SUPPORT		1
7	LEG ADJUSTMENT FRAME		1
8	LEFT HANDLE		1
9	RIGHT HANDLE		1
10	FOAM TUBE		1
11	BACKREST BOARD		1
12	FRONT BASE END CAP		1
13	REAR BASE END CAP		2
14	SLEEVE		2
15	LOCK KNOB	M18	2
16	HANDLE GRIP	150mm	2
17	FOAM ROLL END CAP		2
18	FOAM ROLL		2
19	BOLT COVER CAP	M10	22
20	SQUARE END CAP	40mm x 20mm	6
21	LEG ADJUSTMENT FRAME END CAP	PT30mm x 70mm	1
22	SQUARE END CAP	38mm	2
23	D-SHAPED END CAP		2
24	ALLEN BOLT	M8 x 35mm	2
25	ALLEN BOLT	M8 x 55mm	2
26	HEX BOLT	M8 x 70mm	4
27	HEX BOLT	M10 x 55mm	6
28	HEX BOLT	M10 x 80mm	6
29	HEX BOLT	M10 x 100mm	1
30	AIRCRAFT NUT	M10	13
31	ACORN NUT	M8	4
32	WASHER	Ø 8mm	8
33	WASHER	Ø 10mm	22
34	BENT WASHER	Ø 8mm	4
35	LARGE WASHER	Ø 10mm x Ø 30mm	4
36	END CAP	Ø 50mm	1